



replacement parts industries, inc.

CALL 800-221-9723 or 818-882-8611 • FAX 818-882-7028  
E-MAIL: techsupport@rpiparts.com • WEBSITE: www.rpiparts.com

"The Alternate Source™"

## RPI PART #SCT030 THERMOCOUPLE INSTALLATION INSTRUCTIONS

1. Disconnect the power to the sterilizer. Remove the cover. Disconnect the two cables from the main PC board - one cable from the LCD and the other from the keypad.

2. Inspect the old Thermocouple's tip position from the inside of the cassette bay (armature) for later reference. See **Figure 1**.

If replacing the Thermocouple because of a bent tip, straighten to allow for removal.

3. Disconnect the three (3) Thermocouple wires at the main PCB (see **Figure 2**) and cut all securing cable ties. At the rear of the probe bracket, locate the old thermocouple fitting and loosen the large inner compression nut, then slide out the old Thermocouple with the small compression fitting assembly (see **Figure 5**).

4. Measure the old Thermocouple from the tip to the end of the compression fitting assembly - as shown in **Figure 4**.

5. Use the measurement from Step #4, and apply that same measurement to the new Thermocouple. If the Thermocouple is missing or broken, use 2-3/8" as the dimension for the new Thermocouple.

**NOTE:** For proper function, it is very important that the same measurement from the old Thermocouple is applied to the new Thermocouple so that the position of the new assembly when installed is the same as the old assembly.

6. Hand tighten the small compression fitting nut down onto the new Thermocouple and re-check the measurement. Using two (2) 5/16" wrenches, tighten down the small compression nut.

**CAUTION:** Once the fittings are secured with the wrenches, the position cannot be changed. Now make a pencil mark on the top of the small hex adapter (see **Figure 5**).

7. Pre-bend Thermocouple tip as shown (see **Figure 4**). Insert the new Thermo-

**FIGURE 1**

Internal View of  
Cassette Bay (Armature)

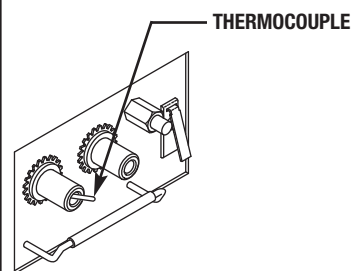

**EXAMPLE OF  
CORRECT  
THERMOCOUPLE  
POSITIONING**

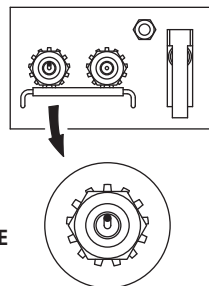

couple Assembly back into the probe bracket assembly and hand tighten the large compression fitting nut (see **Figure 5**). Be sure to keep the bend upwards by ensuring the mark on the small compression fitting nut is up. See **Figure 4 & 5**.

8. Look inside the cassette bay (armature), verify that the tip of the new Thermocouple is positioned slightly upwards as shown in **Figure 1**. Tighten the large compression nut using one 5/16" wrench and one 1/2" wrench.

9. Carefully insert the cassette to verify proper fit.

10. Bend the outer part of the new Thermocouple up and over the probe bracket. **CAUTION:** Do not make sharp bends or kink the new Thermocouple Tube. Maintain a minimum bend radius of 3/16" (5mm). See **Figure 4**.

**FIGURE 3**

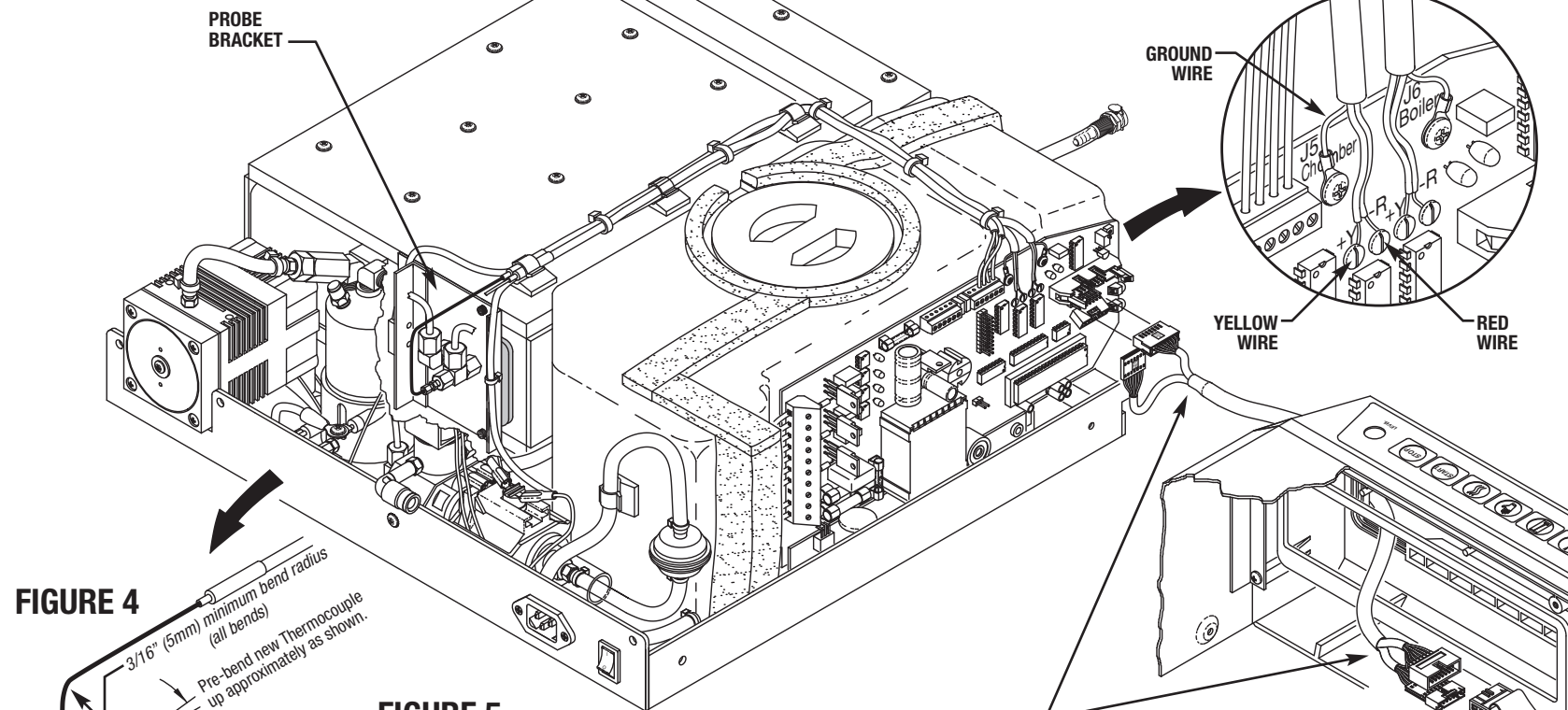

**FIGURE 2**

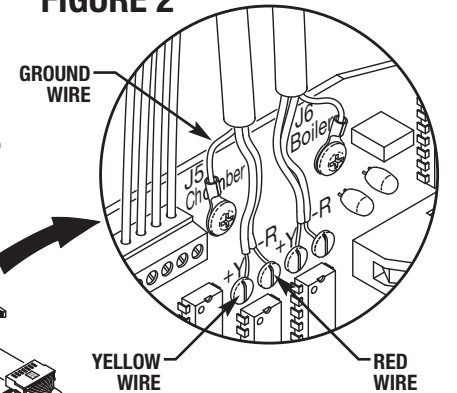

**FIGURE 4**

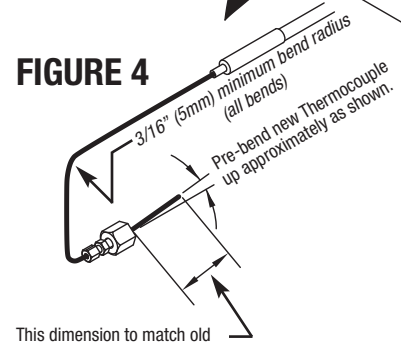

This dimension to match old Thermocouple dimension.  
**Note:** If the Thermocouple is missing or broken, use 2-3/8" as the dimension for the new Thermocouple.

**FIGURE 5**

Mark a line on small hex adapter to indicate upward bend direction of Thermocouple.

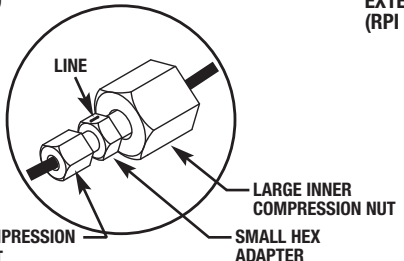

11. Run the wiring back to the main PCB, secure using the Cable Ties (RPI Part #RPT083) provided in this package. Refer to **Figure 3**.

12. Reconnect the ribbon cables from the cover to the main PCB. For ease of testing use an Extension Test Cable (RPI Part #SCT026). See **Figure 3**.

13. Reconnect to power and run an "unwrapped cycle" and check for steam leaks at all new and existing connections. If leaks are found, repair them and repeat testing as necessary.

14. If attached, remove RPI Extension Test Cable and replace the cover. Repeat test cycle.

For Probe Bracket realignment or replacement see backside of this instruction sheet.



replacement parts industries, inc.

CALL 800-221-9723 or 818-882-8611 • FAX 818-882-7028  
E-MAIL: techsupport@rpiparts.com • WEBSITE: www.rpiparts.com

To Fit STATIM® 2000

RPI PART #SCK038 PROBE BRACKET KIT  
RPI PART #SCB039 PROBE BRACKET

To Fit STATIM® 5000

RPI PART #SCK042 PROBE BRACKET KIT  
RPI PART #SCB043 PROBE BRACKET

## INSTALLATION INSTRUCTIONS

1. Disconnect the power to the autoclave and remove the cover.
2. Disconnect existing plumbing, thermocouple and microswitch. Then remove probe bracket assembly using 9/64" Hex Balldriver (RPI Part #RPT836).
3. Remove Probe Bracket Gasket completely, prepare surface and install new Probe Bracket Gasket (RPI Part #SCG010).
4. If reusing existing Microswitch (RPI Part #SCK007), clean silicone adhesive from switch housing. Apply Silicone Gasket Maker (RPI Part #RPS639) or any silicone adhesive to side of switch which mounts to bracket angle. Attach Microswitch to probe bracket. Apply a sealing bead of Gasket Maker around switch housing to close off any leak paths between switch housing and bracket.
5. Remove and discard protective tubing from steam ports and re-install new probe bracket assembly, leave mounting screws loose for port fitting alignment.

**CAUTION:** To avoid steam leaks or damage, Probe Bracket Steam Ports must be properly aligned to Cassette. Use of Alignment Tool is highly recommended.

6. Remove Cassette Seal (RPI Part #SCS001 - STATIM 2000, and SCS029 - STATIM 5000) from cassette. Start with any of the (4) corners and begin prying the Cassette Seal loose using the Cassette Seal Removal Tool (RPI Part #RPT372) or other suitable tool. Once the first corner is free, take hold of the Cassette Seal and pull down and out in order to remove it from the cassette groove. Be careful not to tear the (2) locating tabs in each corner of the Cassette Seal. Thoroughly clean entire seal groove.
7. Install Alignment Tool (RPI Part #SCT052) into cassette (**see Alignment Tool Installation at right**) and align steam port fittings (**see Alignment instructions at right**).  
**NOTE:** If using OEM alignment tool, consult OEM's instructions.
8. After alignment of probe bracket steam ports, re-install plumbing and Thermocouple (RPI Part #SCT030). Thermocouple tip must be properly bent and installed. **See backside of this instruction sheet.**
9. Installation is now complete.
10. Reconnect the ribbon cables from the cover to the main PC board. For ease of testing use an Extension Test Cable (RPI Part #SCT026). **See Figure 3 on the backside of this instruction.**
11. Connect to power and run a few test cycles looking for steam leaks. **NOTE:** During the test cycle, it is normal to hear a hissing sound at first. The sound is from the excess liquid soap expelling and the cassette seal seating in place.
12. Coat the entire inside of cassette with Sci-Dry™ (RPI Part #SCA054).
13. Re-install cover. Sterilizer is now ready to be put back into service.

## RECOMMENDED FIELD SERVICE SMART KIT® (RPI PART #SCK028) TOOLS

### TO USE FOR BRACKET INSTALLATION:

- Alignment Tool (RPI Part #SCT052)
- Cassette Removal Tool (RPI Part #RPT372)
- Hex Balldriver (5/64") (RPI Part #RPT297)
- Hex Balldriver (9/64") (RPI Part #RPT836)
- Liquid Soap (RPI Part #RPS287)
- Extension Test Cable (RPI Part #SCT026)

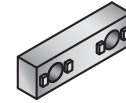

SCT052

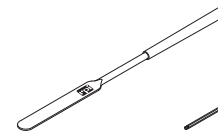

RPT372

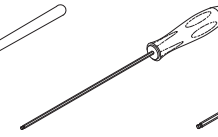

RPT297

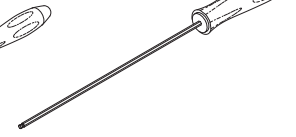

RPT836



RPS287



SCT026

## ALIGNMENT TOOL INSTALLATION

**SERVICE TIP:** Angle cassette lid as shown, using gravity to aid in tool positioning while assembling and closing the cassette.

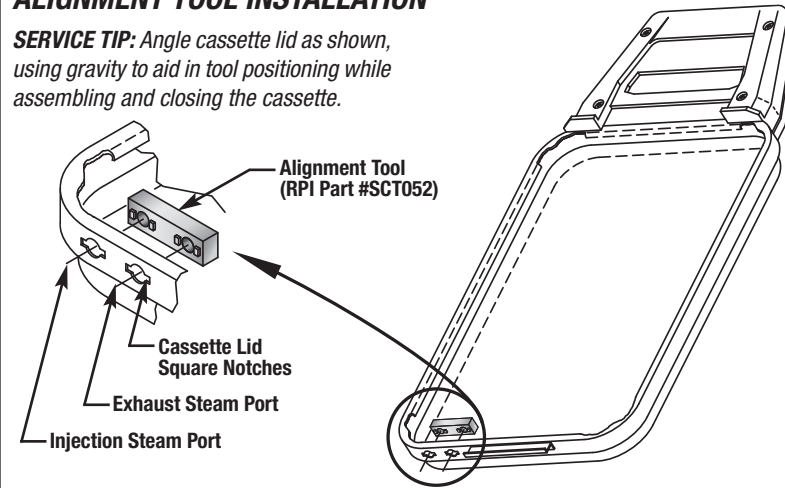

Separate cassette tray from cassette lid. Place lid on counter top and remove cassette seal. Cassette seal must be removed before continuing with Alignment Tool installation.

### Alignment Tool Installation Instructions:

1. Tilt cassette lid and install Alignment Tool (RPI Part #SCT052) into steam ports from the inside of the cassette lid as shown. The square tabs on the tool must engage the square notches in the cassette lid, and the tool must lay flat within the cassette seal groove. The Alignment Tool must be seated correctly to avoid damaging the tray when latched and closed.

**CAUTION:** Ensure that the Alignment Tool is properly installed before closing cassette lid or damage can occur.

2. Carefully attach the bottom tray to cassette lid and close to properly retain the Alignment Tool. Cassette lid should close normally and retain the Alignment Tool. **DO NOT FORCE IT CLOSED!**
3. Cassette is now ready to be used to align probe bracket steam ports.

## ALIGNMENT INSTRUCTIONS

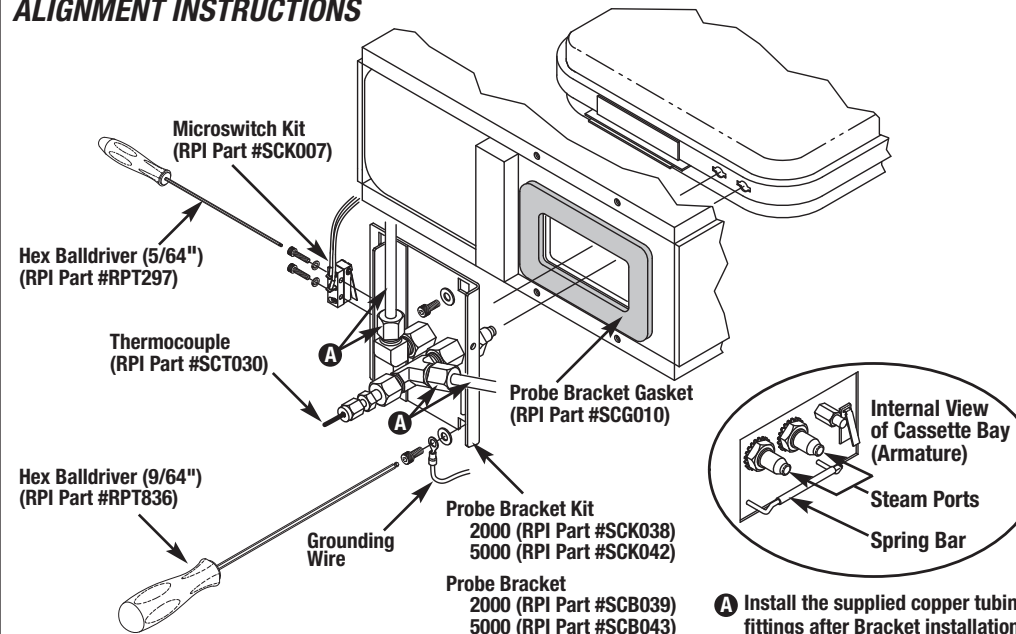

1. Slowly insert the cassette into the cassette bay (armature). As the cassette approaches the probe bracket (still loosely installed), adjust the bracket assembly up and down and sideways until probe bracket steam ports and cassette engage easily. Once properly inserted, the spring bar should engage and lock the cassette into position. A 'click' will be heard and felt.
2. Lightly snug the probe bracket mounting screws. Move the cassette in and out several times to ensure proper alignment. Leave the cassette in the engaged position. Now tighten mounting screws to retain bracket position. The probe bracket assembly is now aligned and ready for use.
3. Remove Alignment Tool. Reinstall or replace Cassette Seal (RPI Part #SCS001 fits STATIM 2000 & RPI Part #SCS029 fits STATIM 5000) using Liquid Soap (RPI Part #RPS287) included with the probe brackets. For additional information regarding the care and maintenance the cassette seal, **see "Installation and Monthly Maintenance Guide"** supplied with our Cassette Seals or from the RPI website [www.rpiparts.com](http://www.rpiparts.com).