



replacement parts industries, inc.

"The Alternate Source™"

CALL 800-221-9723 or 818-882-8611 • FAX 818-882-7028  
E-MAIL: techsupport@rpiparts.com • WEBSITE: www.rpiparts.com

## RPI PART #SCT052 ALIGNMENT TOOL INSTALLATION INSTRUCTIONS

Separate cassette tray from cassette lid. Place lid on counter top and remove cassette seal. The cassette seal must be removed before continuing with Alignment Tool installation.

### Alignment Tool Installation Instructions:

1. Tilt the cassette lid and install Alignment Tool into steam ports from the inside of the cassette lid as shown. The square tabs on the tool must engage the square notches in the cassette lid, and the tool must lay flat within the cassette seal groove. The Alignment Tool must be seated correctly to avoid damaging the tray when latched and closed. **See Figure 1.**

**Caution** - Ensure that the Alignment Tool is properly installed before closing cassette lid or damage can occur.

2. Carefully attach the bottom tray to cassette lid and close to properly retain the Alignment Tool. Cassette lid should close normally and retain the Alignment Tool. **DO NOT FORCE IT CLOSED!**
3. Cassette is now ready to be used to align probe bracket steam ports.
4. If realigning existing probe bracket, loosen (**DO NOT REMOVE**) 4 mounting screws (using 9/64" Hex Balldriver - RPI Part #RPT836) and compression fitting connections to allow repositioning of probe bracket steam ports.

FIGURE 1

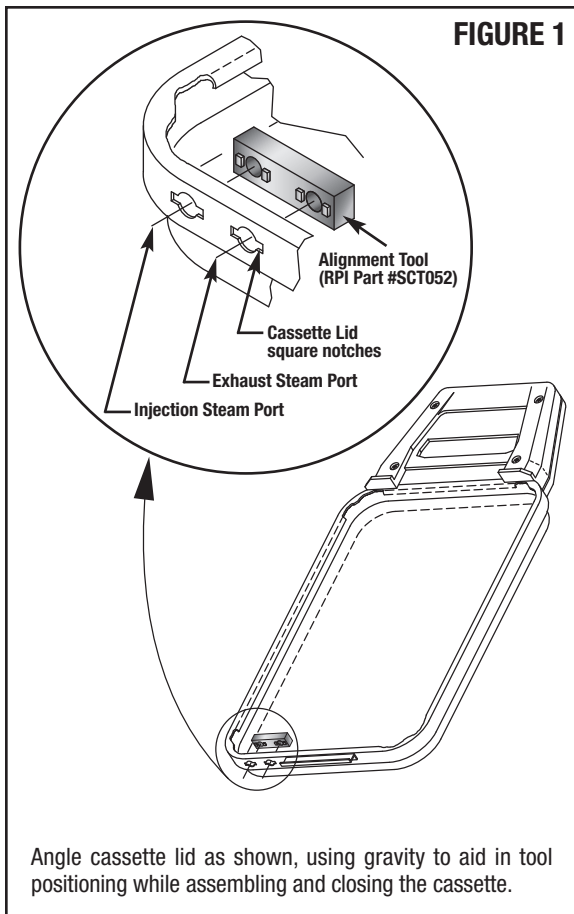

Angle cassette lid as shown, using gravity to aid in tool positioning while assembling and closing the cassette.

## FIGURE 2 ALIGNMENT INSTRUCTION

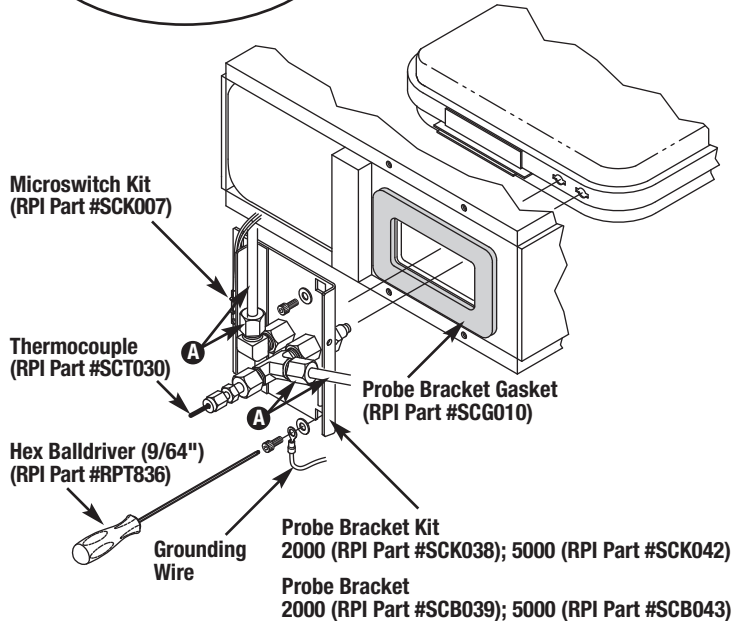
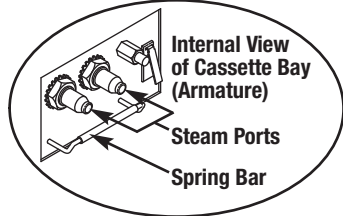

**A** Install the supplied copper tubing and fittings after Bracket installation

5. Slowly insert the cassette into the cassette bay (armature). As the cassette approaches the probe bracket (still loosely installed), adjust bracket assembly up and down and sideways until probe bracket steam ports and cassette engage easily. Once properly inserted, the spring bar should engage and lock the cassette into position. A "click" will be heard & felt. **See Figure 2.**

6. Lightly snug the probe bracket mounting screws. Move the cassette in and out several times to ensure proper alignment. Leave the Cassette in the engaged position. Now tighten mounting screws to retain bracket position. The probe bracket assembly is now aligned and ready for use.

7. Remove Alignment Tool. Reinstall or replace Cassette Seal (RPI Part #SCS001 fits STAT/M® 2000 & RPI Part #SCS029 fits STAT/M® 5000) using Liquid Soap (RPI Part #RPS287) included with the probe brackets. For additional information regarding the care and maintenance of the cassette seal, **see "Installation and Monthly Maintenance Guide"** that is supplied with our Cassette Seals or from the RPI website [www.rpiparts.com](http://www.rpiparts.com).

8. Coat entire inside of Cassette with Sci-Dry™ (RPI Part #SCA054).